

SOLAR BLADE NANOSATELLITE DEVELOPMENT

Richard Blomquist
Carnegie Mellon University
5000 Forbes Ave., Pittsburgh, PA 15213
rsb@frc.ri.cmu.edu

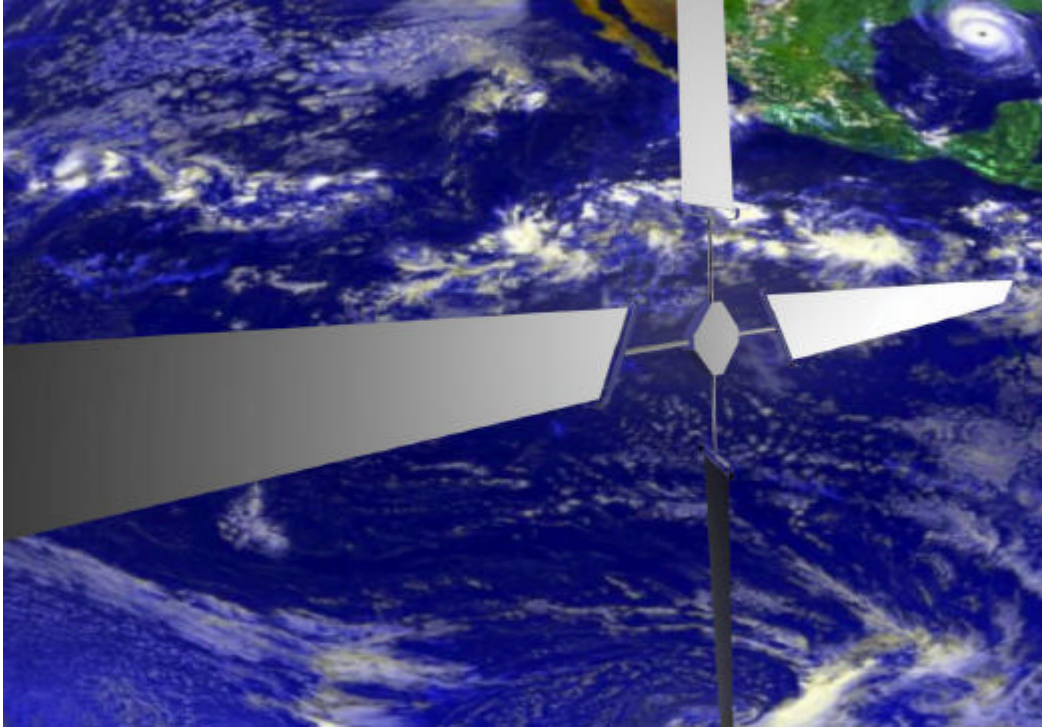

Abstract

Nanosats are a new class of low mass satellite amenable to solar pressure propulsion. Carnegie Mellon Proposes to develop and fly the first spacecraft which utilizes solar radiation pressure as its only means of enabling attitude precession, spin rate change and orbital velocity changes. The Solar Blade Nanosatellite has the appearance of a Dutch windmill and employs control akin to a helicopter. Four solar reflecting blades are mounted radially from a central spacecraft bus and actuated along their radial axis. The satellite's flight dynamics are controlled through the rotation of these solar blades relative to the sun's rays. The spacecraft is stowable in a package approximately the size of a fire extinguisher and weighs less than 5 kilograms. The satellite will demonstrate attitude precession, spin rate management, and orbital adjustments.

Introduction

Carnegie Mellon University is embarking on an effort to fly the first solar sail, a spacecraft that utilizes solar radiation pressure as its only means of propulsion and attitude control. Solar sail concepts have existed for decades, but their implementation has been elusive; to date, no true solar sail craft have flown in space. The primary difficulty with solar sails has been the need for great sail surface area relative to the payload mass. Also, the cost associated with manufacturing very large sails and the risks of deploying such structures in space has hindered their development. For example early solar sail spacecraft designs with payloads weighing hundreds of kilograms in mass led to sails with dimensions of kilometers.^{1,2}

Carnegie Mellon University will employ nanosat technology to dramatically reduce spacecraft payload mass, which shrinks the size of the sail and overall spacecraft mass. This reduction of size and weight makes a heliogyro type sail design eminently more practical and flyable than previous solar sail spacecraft.

The promise of solar sailing in space is in the continuous propulsion derived from natural solar pressure. The absence of a conventional propulsion system aboard the spacecraft means a smaller

spacecraft can carry larger payloads. Another advantage is that solar sailing makes possible exotic missions once thought impractical due to their large propellant requirements. Such missions include dwelling at Lagrange points, hovering over an Earth pole and cruising to asteroids.

Satellite Physical Description

The Solar Blade Heliogyro Nanosatellite has the appearance of a Dutch windmill and employs sail control akin to a helicopter. Four solar reflecting blades are attached to a central spacecraft bus and are pitched along their radial axis. The satellite uses collective and cyclic pitch of these solar blades relative to the sun's rays to control attitude and thrust. The spacecraft weighs less than 5 kilograms, and, when stowed, is a package approximately the size of a fire extinguisher.

Each blade of the Solar Blade is a 20 meter long by 1 meter wide aluminized Kapton sheet 8 microns thick. Edge reinforcing Kevlar and battens of 80 micron-thick Kapton provide added stiffness and resistance to tears. Small brushless motors rotate the blades.

Solar Blade Mission

The satellite will demonstrate attitude precession, spin rate management, and orbital adjustments, after which it will sail out past the orbit of the moon. In addition to attitude and orbital maneuvering, the ultra-light sailing spacecraft will maintain a close proximity to an observation spacecraft, flying in tandem for the first stage of the mission. During this time, formation-flying techniques will aid the observation vehicle in providing images of the operational solar sail from varying vantage points. Both spacecraft will communicate with the Earth, uplinking commands, downlinking images, and relaying orbital and attitude information to ground stations.

The preferred launch vehicle option for Solar Blade is as a secondary payload aboard a Delta II. The schedule for the Solar Blade launch is early 2001. Station-keeping maneuver tests with the solar sail in Earth orbit span a month. Then Solar Blade will attempt an outward spiral voyage to the Moon and will endeavor to sail beyond lunar orbit in late 2002.

Solar Pressure

Solar Sailing Technology Review

Electromagnetic radiation from the sun is partly reflected and partly absorbed when it strikes an object. The normal pressure due to the momentum change of the photons that are reflected is given by the following expression:

$$p_r = p_o f_r \cos^2 \theta \quad (1)$$

where p_o is the total pressure due to normal incidence on the object, equal to about 9 micronewtons per square meter at the Earth's distance from the sun, f_r is the coefficient of reflectivity of the object's surface, and θ is the angle between the surface normal and the incident radiation. The part that is absorbed exerts a pressure given by

$$p_a = 1/2 p_o (1 - f_r) \cos \theta \quad (2)$$

in the direction of the incident radiation. The components of pressure can be divided into pressure parallel to the incident illumination and pressure perpendicular to the illumination, or drag pressure and lift pressure, respectively. Thus, drag and lift can be described by the following expressions:

$$p_d = p_o (f_r \cos^3 \theta + 1/2 (1 - f_r) \cos \theta) \quad (3)$$

$$p_l = p_o (f_r \cos^2 \theta \sin \theta) \quad (4)$$

If in orbit about the sun, the drag on a flat solar sail acts away from the sun and the lift acts in the direction of orbital motion. The drag, as it pushes the craft out from the sun, increases the equilibrium orbit radius slightly. The lift, however, causes the sail to continuously accelerate, resulting eventually in large increases in the orbital radius.

The solar wind also exerts a force on a body in space, but the pressure is a few orders of magnitude less than the photon pressure and is ignored in this analysis. However, the erosion of the solar sail material due to the high-speed particles of the solar

wind may have deleterious effects for missions of long duration.²

The effectiveness of the solar pressure on propulsion can be expressed by a parameter called the lightness number, λ , defined as the ratio of the radiation force on the sail to the gravitational force due to the sun, or

$$\lambda = p_o A / F_G \quad (5)$$

where A is the sail area and F_G is the gravitational force due to the sun. This parameter is invariant with respect to distance from the sun because both the radiation force and the gravitational force vary inversely with the square of the distance from the sun. The lightness number is related to the mass loading of the spacecraft by the expression

$$\lambda = 0.00152 (A/m) \quad (6)$$

where m is in kilograms and A is in square meters.

Another way of looking at solar pressure effectiveness is the resultant acceleration. The maximum possible acceleration of the sail in the vicinity of the Earth is given by

$$a = p_o A/m = 5.92 \times 10^{-3} \lambda \quad (7)$$

where a is in m/s^2 . Therefore, a solar sail with a lightness number of .2 could experience an acceleration of about 1.2 mm/s^2 . Such a sail could ideally undergo an increase in velocity of 102 meters per second per day.

Earth Escape Using Solar Pressure

A sample calculation of the time necessary to escape Earth orbit illustrates the effect of solar pressure on a solar sail. The calculation follows a derivation by Norman Sands³ and assumes a square, flat sail that pitches at a rate equal to half the orbital rate, as shown in Figure 1 below.

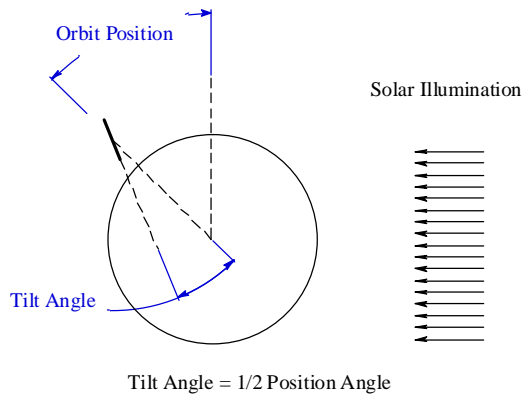

Figure 1. Earth Escape Proposed by Sands³.

The problem is posed as a two-body problem in 2-D space with an initial altitude of 10000 km. Numerically integrating the equations of motion for the two-body problem,

$$d^2 r/dt^2 - r (d\phi/dt)^2 = -\mu/r^2 + F_r/m \quad (8)$$

$$2 dr/dt d\phi/dt + r d^2 \phi/dt^2 = F_t/m \quad (9)$$

where F_r and F_t are the radial and tangential components of force from the Sun, results in the following.

Table 1. Representative time for a Solar Sail to Escape Earth Orbit.

Lightness #	Days to	Orbits to
λ	Escape	Escape
5	4	5
4	16	7
3	9	9
2	22	14
1	35	28
0.5	139	57
0.1	882	286
0.05	1277	572

The maximum possible lightness number of a material, determined by a balance between thickness and opacity, is about 5³. The theoretical limit, then, for Earth escape is 4 days using solar pressure. The trajectory for a sail with a lightness number of 5 appears in Figure 2 below.

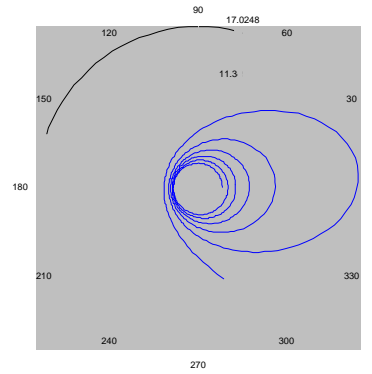

Figure 2. Earth Escape Trajectory for a Solar Sail With $I = 5$.

Sail Material

One of the most important parameters involved in determining solar sail performance is the thickness of the sail material. The material for the maximum lightness number of 5 would be too thin and fragile at .217 microns to be presently practical, due to the necessity of folding the sail for launch into space. However, a method of constructing ultrathin metallic sail material in space has been proposed⁴ and may be accomplished in the future.

Usually, a thin metallized film, such as aluminized Mylar or Kapton®, is proposed for the sail material. Both Mylar and Kapton are commercially available in large quantities in .8 micron thicknesses and in 1.5 meter widths, which make them very suitable for the heliogyro. In fact, Aluminized 8 micron Mylar has been produced in large quantities before, for the Echo I and Echo II balloons⁵, and was shown to hold up well in a space environment. Samples of 1.3 micron Mylar have been made, but large quantities at that thickness would require tooling up at a prohibitive cost.⁶

Figure 3 shows the relationship between non-sail weight fraction, lightness number, and sheet thickness for a Kapton sheet with an aluminum coating 3000 Angstroms thick. For a given thickness, the tradeoff existing between performance and payload is evident. From the figure, the non-sail weight fraction for a solar sail made of commercially available 7.62 micron (.3 mil) Kapton is approximately one-fourth if its lightness number is equal to .1.

Legend: --- $\lambda = .05$ ooo $\lambda = .10$
 ++ $\lambda = .20$ -- $\lambda = .4$
 -●- $\lambda = .80$

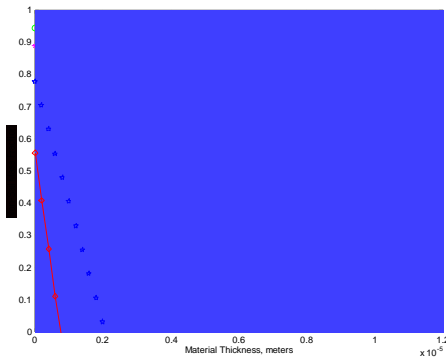

Figure 3. Non-sail weight fraction for heliogyro with Kapton blades and 3000 Angstroms of aluminum coating.

Material Coatings

Two metal coatings best meet the requirements for solar sails: silver and aluminum.⁷ Silver has a higher overall reflectivity than aluminum, but has a transparent window in the ultraviolet region of the electromagnetic spectrum. Ultraviolet radiation could penetrate the silver coating and degrade the sail material below. Aluminum has a slightly lower reflectivity, but is cheaper, has a full spectrum response, and can better protect the material underneath. This protection is essential if Mylar is used as the base material, due to the susceptibility of Mylar to ultraviolet radiation degradation.

Solar Blade Heliogyro Design

Heliogyro Concept

In 1967, Richard MacNeal introduced a dramatically innovative design concept that ultimately received serious consideration for a viable, working solar sail.⁶ Termed the heliogyro, MacNeal's design consists of long, thin blades connected to a central core. The blades are rigidized by centrifugal force and pitched to provide attitude control, much like a helicopter. The initial design concept had two blades

5700 meters long, 1.5 meters wide, and 6 microns thick, and weighed 250 kg, but MacNeal also conceived of extremely large, advanced configurations over 30 kilometers in radius and weighing 45000 kg.

At first glance, it might seem inconceivable that a very thin sheet of plastic with a large aspect ratio could be sufficiently controlled and pitched, but preliminary studies have indicated that it is possible. In an experiment carried out by Richard MacNeal⁸, a sample blade 80 microns thick, 2 cm wide, and 2 meters long was successfully put through pitch maneuvers in a rotating room. The results from the experiment indicate that the heliogyro concept is feasible.

In fact, in the 1970's a design team from the Jet Propulsion Laboratory (JPL) and NASA's Ames and Langley research centers conducted a heliogyro solar sail design study in 1977-78 for implementation in a 1981 Halley's comet rendezvous mission. The design they came up with was a two-tiered, twelve-blade heliogyro, with the blades 7.5 kilometers long. Although their solar sail design was narrowly beaten out for final consideration for the mission by a solar-powered ion thruster spacecraft, the feasibility of solar sails, particularly heliogyro solar sails, was conceptually proven in their design study.

CMU Solar Blade Concept

CMU is basing its solar sail design on the heliogyro concept. However, the Solar Blade differs fundamentally from MacNeal's proposed spacecraft in size and mass. Enabling technology such as electronics miniaturization allow the Solar Blade to be orders of magnitude smaller. In its entirety, the Solar Blade weighs less than 5 kg. Each of its four blades is an 8 micron thick aluminized Kapton sheet 1 meter wide and 20 meters long. The blades stow as rolls, and attach to a central core structure through thin-walled aluminum struts. Figure 4 shows the sail stowed and attached to a stowage vehicle. Figure 5 shows the stowage vehicle alone.

awkward shape of the envelope is sufficient for short, stubby or tall, thin spacecraft. The space requires the Solar Blade to attach to the rocket from the side of its stowage craft. This leaves the core of the sail craft and half of the stowage craft cantilevered from the center. An illustration of the Solar Blade situated inside the payload envelope appears below in Figure 7.

Figure 4. Solar Blade Spacecraft Attached to Its Stowage Vehicle.

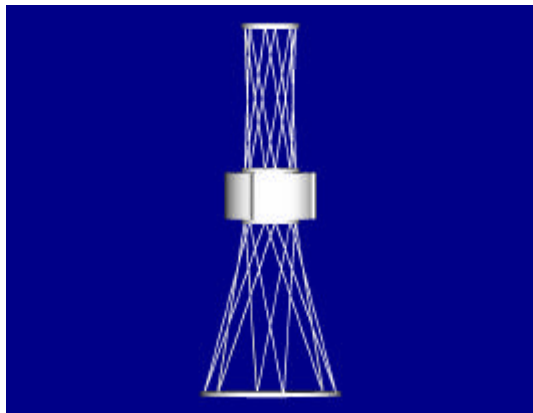

Figure 5. Stowage Vehicle.

Stowage on a Delta II

Atmospheric effects surpass solar pressure effects at altitudes lower than 1000 km. Thus, many LEO launches, including the Space Shuttle, are out of the question for the Solar Blade. Among the secondary launches to higher orbits, a Delta II secondary accompanying an Air Force/GPS primary is favorable for a number of reasons: first, flight slots are available for the desired 2001 time frame; second, the space available on a Delta II secondary is adequate; and third, integration may be easier for an Air Force secondary aboard an Air Force primary launch.

The space available on a Delta II for a typical secondary payload appears in Figure 6 below. The

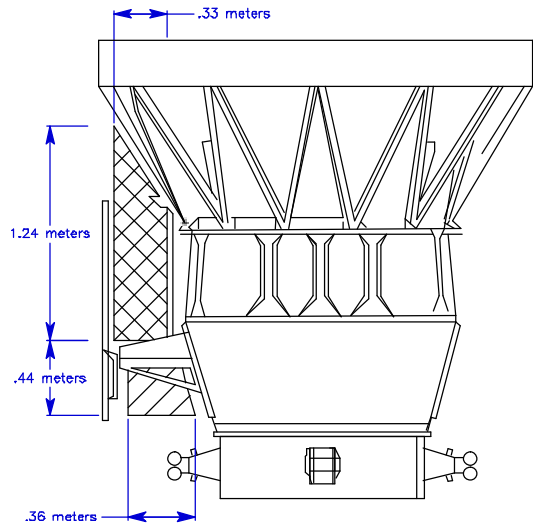

Figure 6. Usable Envelope for a Separating Secondary Payload, Three-Stage Mission.

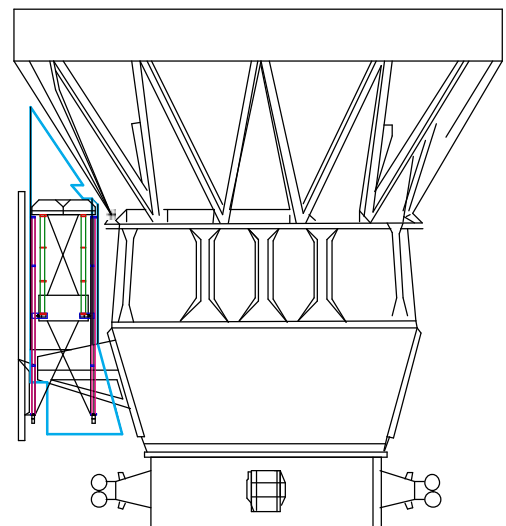

Figure 7. Solar Blade on Delta II.

The stowage vehicle that attaches to the solar sail during stowage is equipped with a cold gas thruster system, batteries, a communication system, and a camera for viewing the deployed solar sail.

The blade rolls register against pivoting clips on the stowage vehicle that hold them in place as long

as the stowage vehicle is attached to the base of the Solar Blade core. A release device keeps the stowage vehicle and the core together until deployment.

Sail Deployment

After the primary payload deploys, explosive bolts release the Solar Blade from the Delta II. Cold gas thrusters on the stowage craft null out the spacecraft tumble, point the sail core at the sun, and spin up the spacecraft to 30 rpm while maintaining line of sight with the sun. With the proper spin rate and orientation obtained, the stowage vehicle/spacecraft core release device fires. Torsion springs drive the struts and blade rolls outward, the blade pitch motors level the blade rolls, and the blade deployment motors slowly and symmetrically feed out the blades. As the blades deploy, a collective pitch maneuver maintains the spin rate.

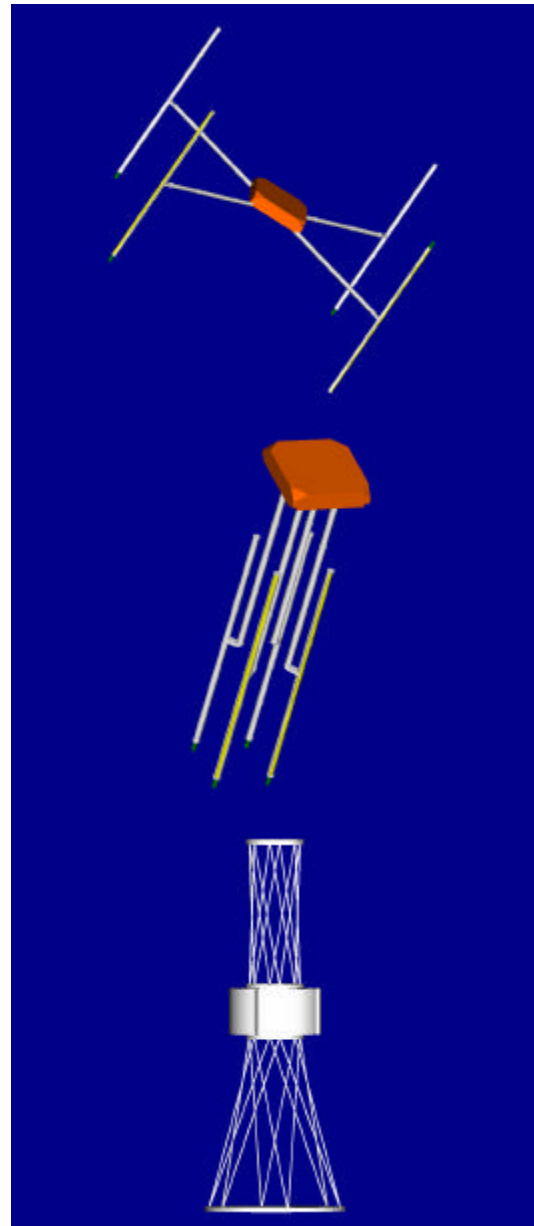

Figure 8. Initial Part of Deployment Sequence. Stowage Vehicle is Left Behind as the Sail Struts and Blades Deploy Outward. The Stowage Vehicle Observes, Taking Pictures and Relaying Them to Earth.

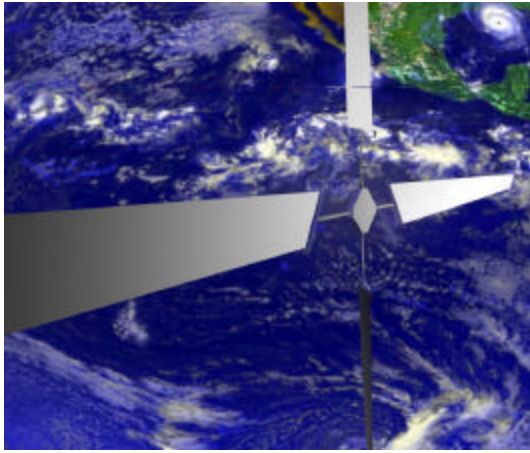

Figure 9. Solar Blade Fully Deployed.

Control Characteristics

The control characteristics of the heliogyro are simply modeled after helicopter controls. By pitching the blades, the sail can achieve all the necessary control responses. The equation for the pitch angle of the blades with conventional helicopter controls is given as

$$\theta = \theta_0 + a_1 \sin(\Omega t - \phi_0) + b_1 \cos(\Omega t - \phi_0) \quad (10)$$

where θ_0 , a_1 , and b_1 vary slowly with time and ϕ_0 is an azimuth reference that is fixed in the non-rotating coordinate system and is usually chosen to coincide with the longitude axis of the helicopter. For the heliogyro, this direction should be connected to the direction of flight. The angle θ_0 is the collective pitch angle, and a_1 and b_1 are the longitudinal and lateral components of cyclic pitch.

Control Maneuvers

Three basic maneuvers are necessary to control the heliogyro: cyclic pitch, collective-cyclic pitch, and collective pitch. The cyclic pitch maneuver produces a steady force in the plane of the heliogyro and is shown in Figure 10. The collective-cyclic pitch maneuver produces a steady rolling moment and spin torque, as illustrated in Figure 11. The vertical components of pressure in positions 1 and 3 in the figure are equal, whereas the vertical component in position 4 is greater than that in position 2. As the spin rate increases with this maneuver, both the collective and cyclic pitch angles must be reversed occasionally during the maneuver to stay near the

desired spin rate and still maintain the same rolling moment. The collective pitch maneuver, shown in Figure 12, produces spin torque and allows the component of force normal to the heliogyro plane to be reduced.

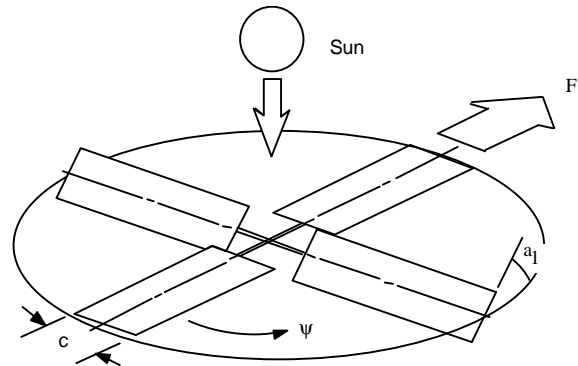

Figure 10. Cyclic Pitch Maneuver.²

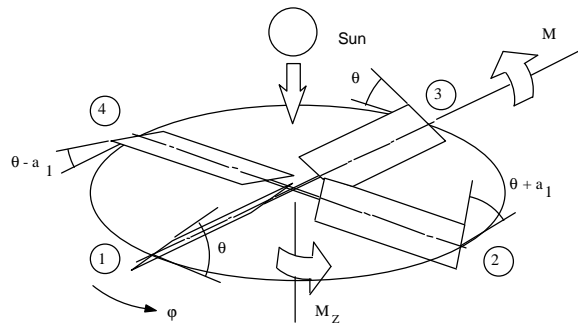

Figure 11. Collective-cyclic Pitch Maneuver.²

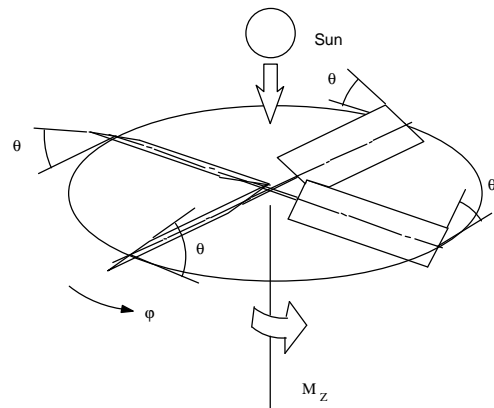

Figure 12. Collective Pitch Maneuver.²

Another helpful maneuver is the half-p pitch. This maneuver was chosen to take the place of the collective-cyclic pitch maneuver by JPL for the Halley's comet mission.⁶ The half-p pitch maneuver is like the collective-cyclic pitch maneuver, as can be seen in Figure 13, except it does not produce spin

torque. The blades are pitched cyclicly every two revolutions. The blade pitch angle for this maneuver is given by (16)

$$\theta_0 + a_1 \sin\phi + b_1 \cos\phi + a_{1/2} \sin 1/2(\phi - \phi_0) \quad (11)$$

where ϕ is the blade azimuthal position in relation to the plane including the sun-line and the spin axis.

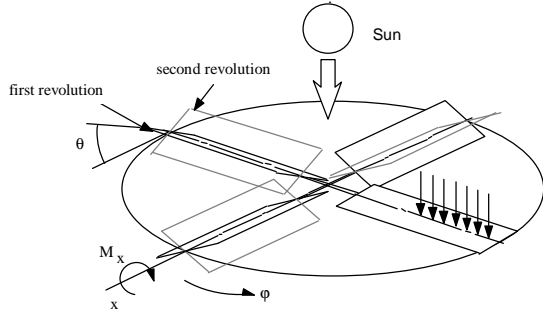

$$\theta = a_{1/2} \sin \frac{1}{2} \left(\phi - \frac{\pi}{2} \right)$$

$$M_x = \frac{3}{16} p_0 A R a_{1/2}^2 + (\text{higher order terms}) \quad (12)$$

Figure 13. Precessional moment due to half-p pitch. ⁶

Avionics

Procuring a small, inexpensive radiation-hardened flight computer is key to keeping mass and costs down. A microcontroller that meets the preliminary needs of the spacecraft is UTMC Corporation’s UT131 16 bit embedded controller. Running at 20 MHz, and with a 1 Mbyte memory, the controller can control the pitch of the motors and the inputs of the attitude and position sensors. Also, an added transceiver package can interface to the communications equipment.

Another item that helps keep mass and cost down is a sun sensor system developed in-house, using solar cells mounted at 45° angles at the corners of the sail core for rough sun position estimation, and an active pixel sensor camera. The avionics will compute the center position of the image of the sun on the sensor and determine the angle of the sun with respect to the core. Figure 14 illustrates the position of the solar cells and the sensor camera in the core, and Figure 15 shows the geometry for sun vector determination. The equation for the sun angle is

$$\theta = \text{atan}(x_i * (z_0 / f - 1) / z_0) \quad (13)$$

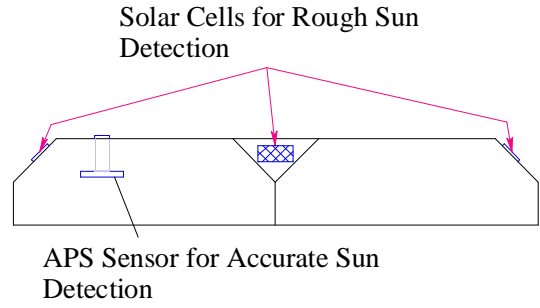

Figure 14. Solar Cell and APS Sun Sensor Locations.

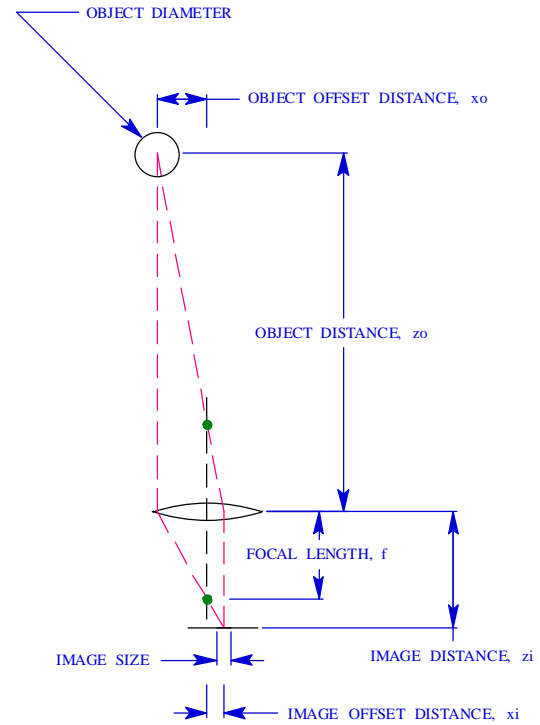

Figure 15. Geometry for sun direction determination.

To determine location in the initial stages of the mission, the spacecraft and stowage vehicle both carry GPS systems. Together with the sun sensors, Mems gyros and Earth sensors, the spacecraft is capable of determining its location and attitude. Because mass is such a commodity on this mission, the smallest possible communications system must be employed. To cut down on the bandwidth, and thus enable the use of small communications components, the spacecraft will use autonomy software developed at CMU. The autonomy capability is cutting edge research and is yet to be developed. It will, however, have as a goal to maintain and control the spacecraft on its own.

An added component to the avionics system is the APS camera system to take pictures of the solar

sail from the stowage vehicle, and an APS camera mounted inside the solar sail core to image the blades. The blade camera has a unique configuration that allows it to view the blades from inside the core. The sensor chip is mounted pointing in the direction of the sun. Two mirrors mounted directly above the camera in a v configuration allow the camera to view outside and down on all four blades at once. The geometry appears in Figure 16.

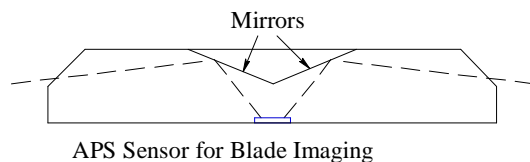

Figure 16. Geometry for Blade Cameras. The Above Image is a Cutaway View of the Location of the APS Sensor and the Mirrors.

Work on the avionics will provide more details as time goes on. At the present time, development and testing of all aspects of the Solar Blade spacecraft is underway, shooting for a launch in early 2001.

Acknowledgments

The program is funded collaboratively by USAF, NASA, the Space Studies Institute, the FINDS Foundation and Carnegie Mellon University. Please feel free to contact Richard Blomquist or Red Whittaker (CMU) if there are any further questions on the Solar Blade project.

References

1. Hedgepath, John, personal communication, May, 1999.
2. MacNeal, R. H., "The Heliogyro, An Interplanetary Flying Machine", NASA Contractor's Report CR 84460, June 1967.
3. Sands, Norman, "Escape From Planetary Gravitational Fields by Use of Solar Sails", ARS Journal, April, 1961, pp. 527-531.
4. Drexler, K. E., "Design of a High Performance Solar Sail System", M.S. Thesis, Mass. Inst. of Tech., May, 1979.

5. Significant Electronic Applications and Experimental Results from Project Echo, Goddard Space Flight Center, Nov. 1965.
6. Friedman, L., et. al., "Solar Sailing- The Concept Made Realistic", AIAA paper 78-82, 16th Aerospace Sciences meeting, Jan. 16-18, 1978.
7. Wright, J. L., Sauer, C. G., Jr., & Chen-Wan-Yen, "Solar Sail Concepts and Applications", World Space Foundation, Sept. 1980.
8. MacNeal, R. H., "Structural Dynamics of the Heliogyro", NASA-CR-1745A, 1971.
9. Boeing Corporation, "Delta Launch Vehicle Secondary Payload Planner's Guide for NASA Missions, 1995.